

DESIGN NOTES

High Performance 3-Phase Power Supply Delivers 65A and High Efficiency Over the Entire Load Range – Design Note 312

Wei Chen

Introduction

CPUs used in notebook computers and other mobile applications now draw more than 30A of current and may draw as much as 65A in the near future. For these heavy loads, high efficiency power supplies are required to protect the system from excessive thermal stress. With this in mind, PolyPhase® switching DC/DC converters have become the standard for CPU power supplies because they are extremely efficient at these heavy loads. Nevertheless, for portable applications that spend much of the time in sleep or standby modes, *light load* efficiency has also grown in importance, where conserving energy for maximum battery run-time is also a priority. Unfortunately, traditional PolyPhase converters, although exceptional performers at heavy loads, do not yield comparable efficiencies at light load. Linear Technology Corporation

offers a solution to this problem with a new family of PolyPhase controllers that allow the design of converters that are efficient over the entire CPU load range.

These new 3-phase controllers, the LTC®3730, LTC3731 and LTC3732, operate efficiently at both heavy loads and light loads. These new controllers introduce Stage Shedding™ operation to improve light load efficiency. Like LTC's 2-phase controllers, these new 3-phase controllers provide true remote sensing on both the positive and negative output rails to ensure tight output regulation at high output currents, and Kelvin sensing (positive and negative) on the pads of each current sense resistor to

LT, LTC and LT are registered trademarks of Linear Technology Corporation. PolyPhase is a registered trademark of Linear Technology Corporation. Stage Shedding is a trademark of Linear Technology Corporation. Pentium is a registered trademark of Intel Corporation.

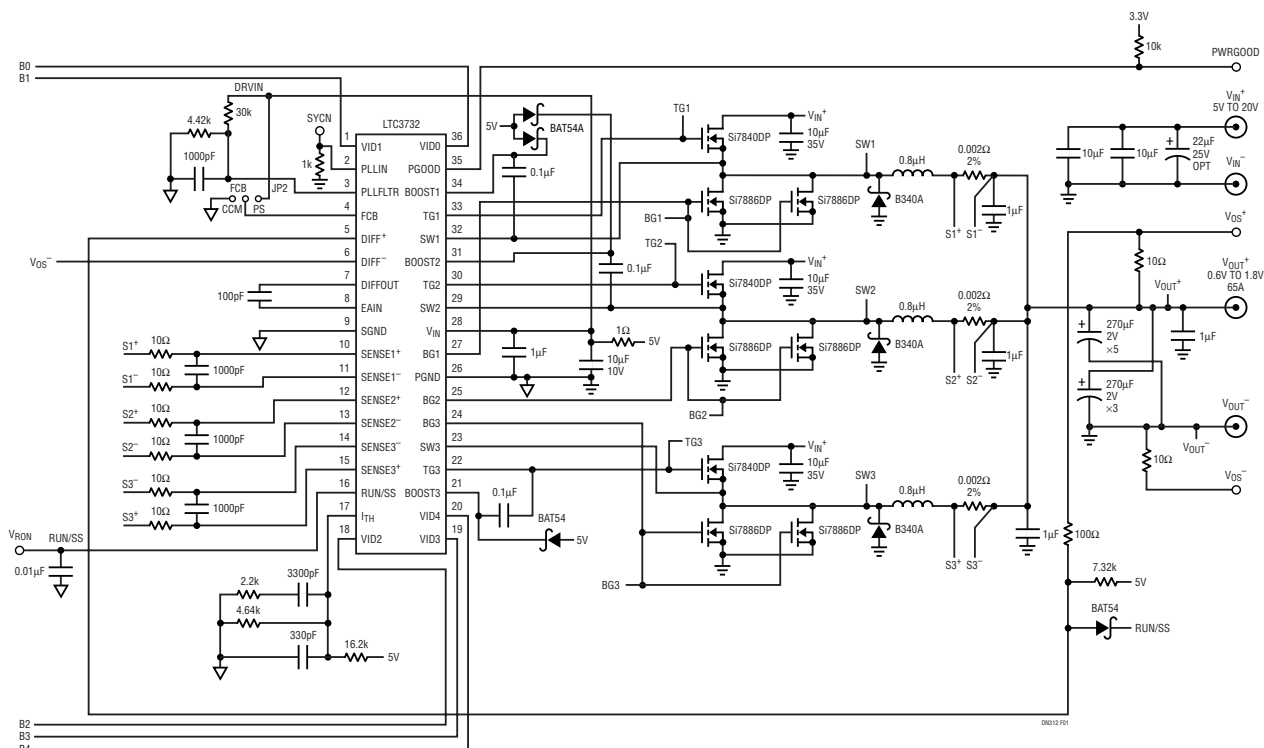

Figure 1. Schematic Diagram of a 3-Phase LTC3732 65A VRM9.x Power Supply

achieve accurate current sharing, even if the layout of parallel power stages is not symmetrical. All controllers feature integrated high current MOSFET drivers for up to 600kHz switching frequency, thus minimizing the overall power supply size and component count.

The LTC3731 is a versatile 3-phase controller that generates a 30 or 60 degree phase-shifted clock output based on the voltage level of the PHASMD pin. This feature allows several LTC3731s to be paralleled for up to a 12-phase operation. The output voltage is programmed by external resistors. The LTC3730 is a dedicated 3-phase controller with 5-bit VID output programming that is compatible with IMVP2 and IMVP3. The internal op amp can be used to program voltage offsets for different CPU operation modes. The LTC3732 is another 3-phase controller with a 5-bit VID output programming that is compatible with Intel's VRM9.x specs. All three controllers are available in space saving 36-lead SSOP packages, while the LTC3731 is also available in a much smaller, thermally enhanced 5mm × 5mm QFN package.

Stage Shedding Operation

In high current applications, low $R_{DS(ON)}$ MOSFETs are typically chosen to minimize conduction losses at full loads. At light loads, though, the high gate charge and parasitic capacitance of these MOSFETs often cause power losses associated with gate driving and switching. Also, the core losses of inductors dominate the overall inductor power losses at light loads. Since the switching losses, gate driving losses and inductor core losses do not decrease with load currents, light load efficiency suffers.

Another cause of low efficiency at light loads is the circulating current among the paralleled stages. In a PolyPhase synchronous buck converter, the inductor current in each synchronous buck stage can reverse at light loads due to synchronous rectification. In a practical PolyPhase design, a current sharing error always exists because of tolerances in the sense resistors and slight differences between paralleled channels within the controllers. Any current sharing error among the paralleled stages introduces circulating currents that introduce additional power losses.

To reduce these light load power losses, Stage Shedding operation shuts down all but one channel, completely

eliminating the circulating currents. Furthermore, this mode eliminates the gate drive losses, MOSFET switching losses and inductor core losses of the unused channels. The result is much higher efficiency at light loads and since the controller maintains the basic regulation loop, Stage Shedding operation has no effect on output regulation accuracy.

3-Phase High Efficiency VRM9.x Power Supplies for Pentium® 4 CPU

Figure 1 shows a 3-phase VRM9.x power supply for a Pentium 4 microprocessor. It uses the LTC3732 to drive nine small PowerPak SO-8 MOSFETs for 65A output current. To provide higher output currents, simply use lower $R_{DS(ON)}$ MOSFETs and higher current rated inductors. R3 and R4 implement a lossless active voltage positioning (AVP) technique to minimize the output capacitor size. For more detailed technical information about AVP, see the LTC1736 data sheet or Design Note 224. Figure 2 shows the measured efficiency under different load conditions. The input is 12V, the output voltage is 1.4V and the switching frequency is 450kHz. Figure 2 shows the efficiencies measured when Stage Shedding operation is enabled and for conventional PolyPhase operation. As the chart shows, Stage Shedding operation significantly improves efficiencies at light loads ($\leq 10A$). For instance, at 1% of full load (0.6A), Stage Shedding operation improves efficiency by more than 25%.

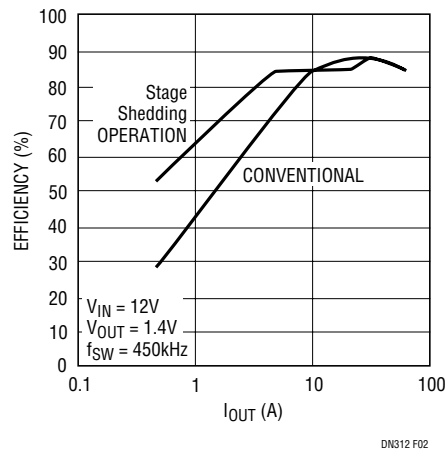

Figure 2. Measured Efficiency (Stage Shedding Operation vs Conventional Operation). Load Range is 0.6A to 65A

Data Sheet Download

<http://www.linear.com/go/dnLTC3730>
<http://www.linear.com/go/dnLTC3731>
<http://www.linear.com/go/dnLTC3732>

For literature on our Controllers, call **1-800-4-LINEAR**. For applications help, call (408) 432-1900, Ext. 2593